

APPROVAL SHEET



FHD ELECTRONICS CORPORATION

CUSTOMER NAME : _____

COMMODITY : Piezo Transducer

FHD PART NO. : T222670-P2000E-J

CUSTOMER PART NO. : _____

Approved by	Y. J.	Prepared by	HY Shen
-------------	-------	-------------	---------

Customer Approval			
Approved		Rejected	

8104 Lynores Way, Plano, TX 75025

Tel: [469-409-2828](tel:469-409-2828) Cell: [408-693-5952](tel:408-693-5952)

Email: sales@fhdmfg.com Website: www.fhdmfg.com

1. Technical Parameter



Measuring condition

Part shall be measured under a condition (Temperature: 5~35°C, Humidity: 45%~85%R.H., Atmospheric pressure: 860 ~ 1060hPa) unless the standard condition (Temperature: 25±3°C, Humidity: 60±10%R.H. Atmospheric pressure: 860 ~ 1060hPa) is regulated to measure.

1	Resonant Frequency	2000Hz
2	Operating Voltage	1~30Vp-p
3	Rated Current	Max.3mA , at 2KHz 50% duty Square Wave 3Vp-p
4	Sound Output at 10cm	Min. 70dB, at 2KHz 50% duty Square Wave 3Vp-p
5	Capacitance	25000±30%pF at 1KHz
6	Operating Temperature	-20°C ~ 70°C
7	Store Temperature	-40°C ~ +80°C
8	Net Weight	Approx 2.5 g
9	RoHS	Yes

2. Dimensions

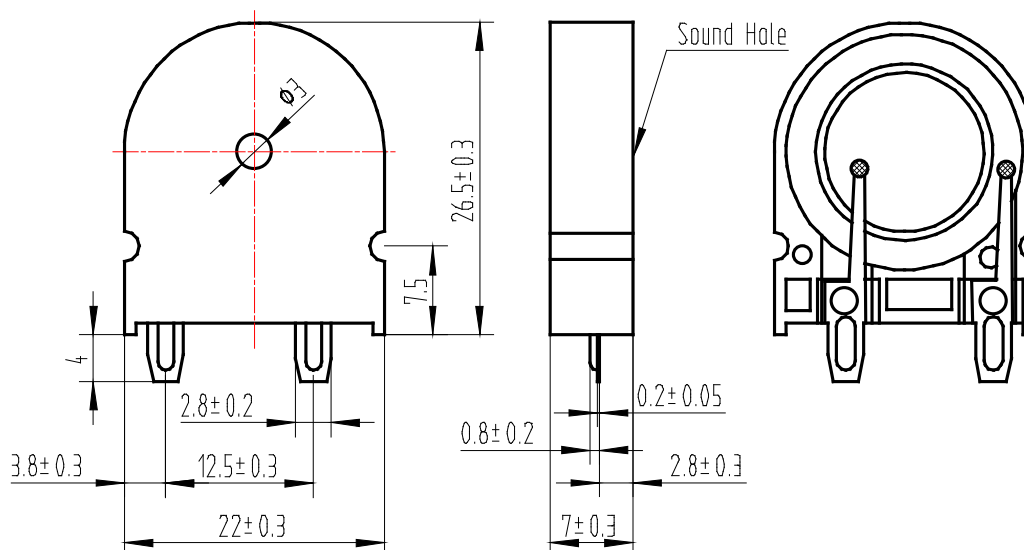

*Unit: mm; Tolerance: ±0.5mm Except Specified

*Housing Material: Black PBT

3. Electrical And Acoustical Measuring Condition

Recommended Setting

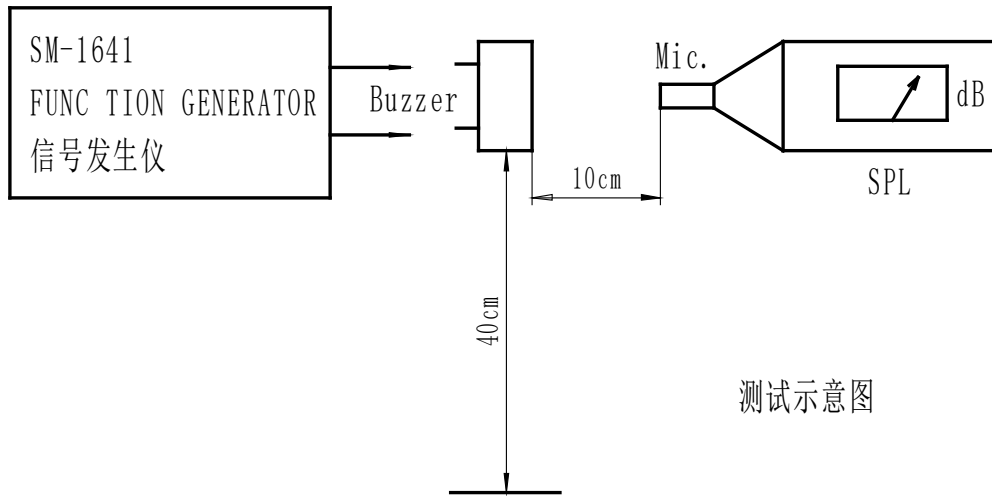

4. Frequency Response

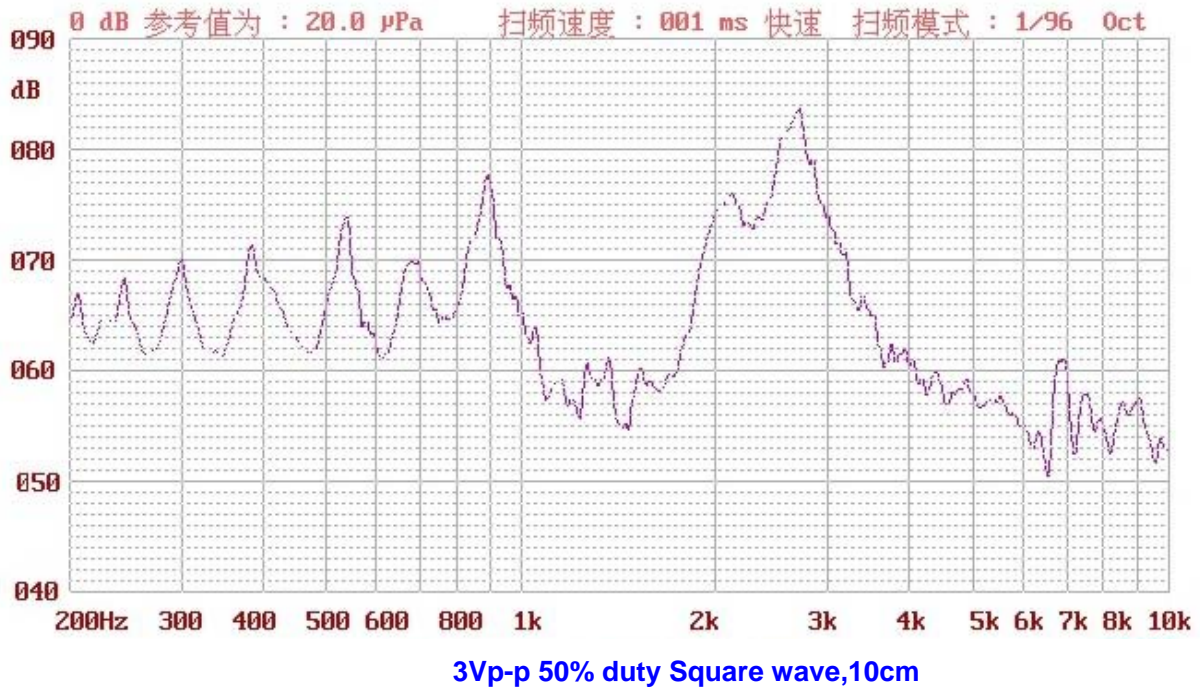

5. Reliability Test

After any following tests the part shall meet specifications without any degradation in appearance and performance except SPL. SPL shall not deviate more than -5 dB from the initial value

5.1. Ordinary Temperature Life Test

The part shall be subjected to 96 hours at $25\pm 10^{\circ}\text{C}$. Input rated voltage
Resonant frequency, 1/2 duty Square wave.

5.2. High Temperature Test

The part shall be capable of withstanding a storage temperature of $+80^{\circ}\text{C}$ for 96 hours.

5.3. Low Temperature Test

The part shall be capable of withstanding a storage temperature of -40°C for 96 hours.

5.4. Humidity Test

Temperature: $+40^{\circ}\text{C}\pm 3^{\circ}\text{C}$ Relative Humidity: 90% ~ 95% Duration: 48 hours and expose to temperature for 6 hours

5.5. Temperature Shock Test

Temperature: 60°C /1hour \rightarrow 25°C /3hours \rightarrow -20°C /1hour \rightarrow 25°C /3hours (1cycle)
Total cycle: 10 cycles

5.6. Drop Test

Product in standard packaging dropped from height 75 cm onto a thick 5 cm hardwood board, three sides, six plain.

5.7. Vibration Test

Vibration: 1000cycles /min. Amplitude: 1.5mm, Duration: 1 hour in each 3 axes

Note:

As this product is not protected from foreign material entering, please make sure that any foreign materials (e.g. magnetic powder, washing solvent, flux, corrosive gas) do not enter this product in your production processes. The functional degradation (e.g. SPL down) may occur if foreign materials enter it.

6. Packing Information

