

APPROVAL SHEET



FHD ELECTRONICS CORPORATION

CUSTOMER NAME : _____

COMMODITY : Mylar Speaker

FHD PART NO. : MS50R078-8T15

CUSTOMER PART NO. : _____



Approved by	Y. J.	Prepared by	HY Shen
-------------	-------	-------------	---------

Customer Approval			
Approved		Rejected	

8104 Lynores Way, Plano, TX 75025

Tel: 469-409-2828 Cell: 408-693-5952

Email: sales@fhdmfg.com Website: www.fhdmfg.com

A. PART NO.: MS50R078-8T15**B. SPECIFICATION**

Test condition: Temperature: 15~35℃ Related Humidity:25~75% (GB/T9396-1966)

No.	Item	Specification	Condition
1	Dimension	Dia. 50 x H7.8mm	
2	Weight	grams	
3	Rated Impedance	8Ω ± 20%	At 1000Hz
4	Resonant Frequency	350Hz ± 20%	At 1Vrms without baffle
5	Output Sound Pressure Level S.P.L.	91±3db (0.1M / 0.1W)	At 0.6, 0.8, 1.0, 1.2KHz (0dB SPL=20uPa)
6	Frequency Range	F0---20000Hz	
7	Distortion	10% Maximum	At1.0kHz
8	Magnet	NdFeB	
9	Power Rating	Normal: 1.5 Watts Maximum: 2.0 Watts	Sine Wave
10	Operating Temp.	- 20 ~ + 60℃	
11	Storage Temp.	- 30 ~ + 70℃	
12	Audible Noise	The input power shall be set at rated noise power (1.5W). Using an audio oscillator sweep from F0 to 10000HZ in free air. There shall be no buzzes and rattles and nor spurious noises.	Sine Wave
13	Polarity	When a positive D.C current is applied to the voice coil terminal marked (+). The diaphragm shall move forward.	
14	RoHS	The Speaker is RoHS compliant.	

C. ENVIRONMENTAL TEST

No.	Item	Condition	Evaluation standard
1	High Temperature	After being placed in a chamber at +70℃±5℃ for 96 hours	Being placed for 6 hours at room temperature, speaker shall be

2	Low Temperature	After being placed in a chamber at $-30^{\circ}\text{C}\pm 5^{\circ}\text{C}$ for 96 hours.	measured. SPL should not deviate by ± 3 db, and resonant frequency should not deviate by ± 80 Hz, compare with pre-test measurement.
3	Humidity Test	After being placed in a chamber at $+40\pm 5^{\circ}\text{C}$ and 90~96%(RH) Relative Humidity for 96 hours.	
4.	Temperature Cycle Test	Temperature: $-30^{\circ}\text{C} \longleftrightarrow 70^{\circ}\text{C}$ Duration: 2hrs 2hrs Cycle: 5 cycles	

D. MECHANICAL AND VIBRATION TEST

No.	Item	Test condition	Evaluation standard
1	Drop Test	Drop from 1.0m height onto concrete floor 6 times	SPL shall not deviate by ± 3 db from pre-test measurement.
2	Vibration Test	Vibration: 10Hz~55Hz Amplitude: 1.5mm or acceleration : 50m/s ² Duration : 2h per axis=10cycles ; 3 axis	

E. RELIABILITY TEST

No.	Item	Test conditions	Evaluation standard
1	Load Test	1.5W White noise is applied for 96hours	Speaker should not fail after apply 20 ~ 20K Hz White noise rated power input (RMS), 100 hours. After test, SPL shall not deviate by ± 3 db from pre-test measurement,

F. MEASUREMENT CIRCUIT

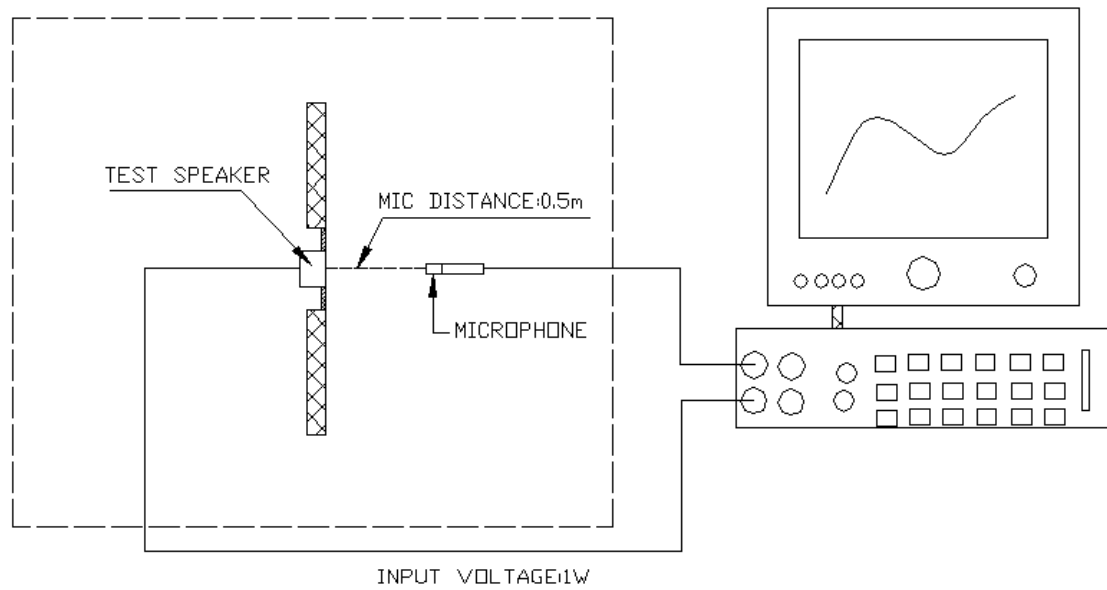

G. DRAWING *Unit: mm; Tolerance: $\pm 0.5\text{mm}$ Except Specified

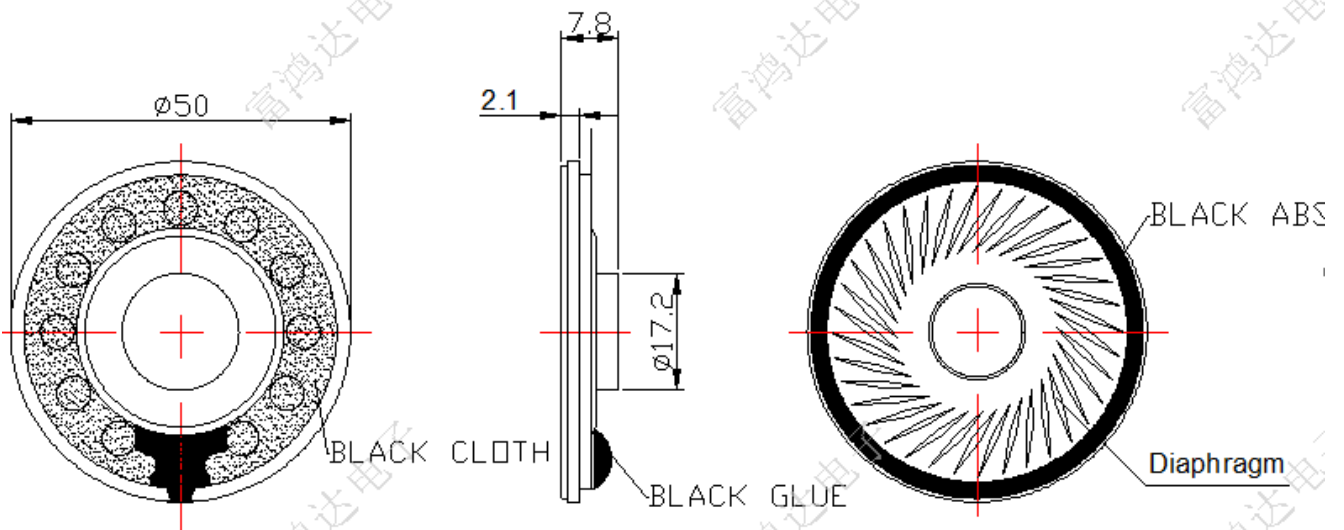

H. SOUND PRESSURE CURVE

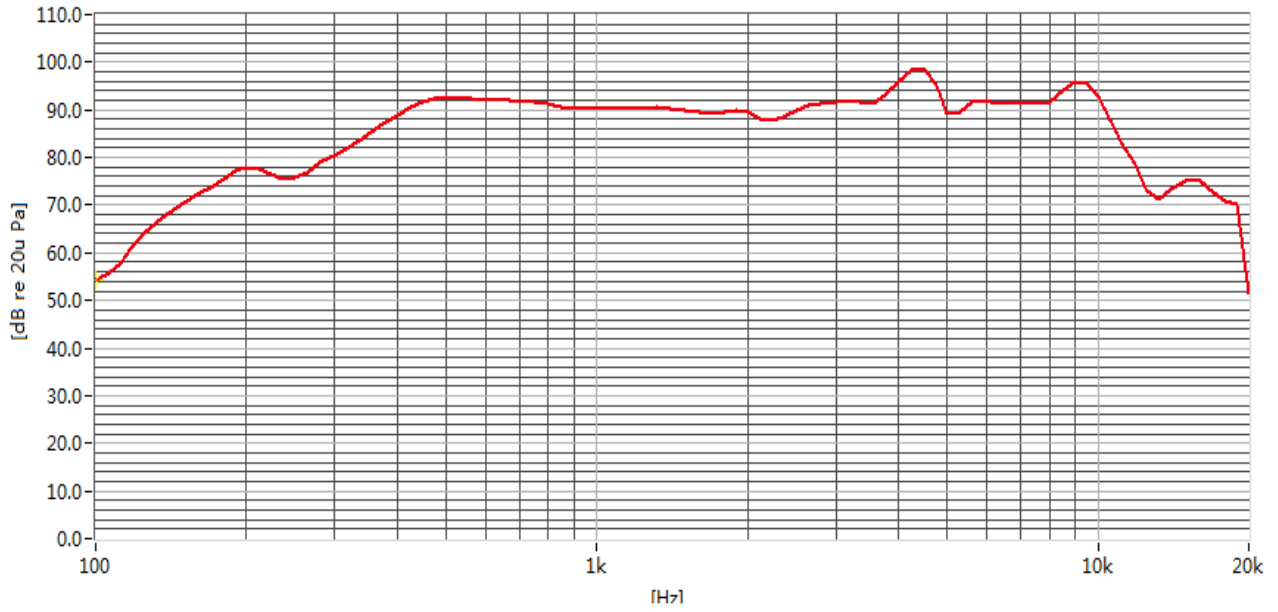

I. PACKING INFORMATION (TBD)